

VACUUM-ASSISTED SELF PRIMING ENGINE DRIVEN PUMPS

MOTOPOMPE AUTOADESCANTI VUOTOASSITITE

RW425+TT

ROBUSTA
Hydraulic System

VIESSE 
POMPE • ITALIA



The vacuum-assisted pumps "Robusta", are designed to comply to the hardest and heavy duty applications, such as: building, emergency and industrial sectors. Unique in the whole world, the opened blades, double curved impeller, grants an high hydraulic efficiency. The high thickness of the casing and of the impeller blades, allow the pumping of more abrasive fluids and larger passage of solids. The great priming capacity of the vacuum device, is making, this unit, particularly suitable for wellpoint systems, having a fast and continuous priming.

FEATURES

- ✓ EN-JL1030 cast iron construction according to UNI EN 1561 with modular body.
- ✓ Replaceable screw-less armoured internal volute in EN-JS1030 nodular cast iron according to UNI EN 1563.
- ✓ Mechanical seal in high resistance hard metal.
- ✓ Large-size inspection hatches to facilitate cleaning and inspection.
- ✓ Standardised EN1092-1:2003 flanged inlet and outlet with built in threaded rod.
- ✓ Rapid self-priming up to 8 meters in vertical position.



Le pompe vuotoassistite "Robusta" sono realizzate per le applicazioni più gravose e difficili nei settori: edilizia, emergenza e industria. La girante a pale aperte e doppia curvatura, unica al mondo, garantisce un elevato rendimento idraulico. Lo spessore del corpo e delle pale della girante permettono di pompare anche i fluidi più abrasivi con elevato passaggio di corpi solidi. Il depressore ad alta capacità di vuoto permette un adescamento rapido e continuo, rendendole particolarmente idonee al servizio wellpoint.

CARATTERISTICHE

- ✓ Costruzione in ghisa EN-JL1030 secondo UNI EN 1561 con corpo modulare.
- ✓ Voluta interna corazzata sostituibile senza viti, in ghisa sferoidale EN-JS1030 secondo UNI EN 1563.
- ✓ Tenuta meccanica ad alta resistenza.
- ✓ Portine di ispezione di grandi dimensioni per facilitarne la pulizia e l'ispezione.
- ✓ Bocche flangiate norm. EN1092-1:2003 con prigionieri.
- ✓ Innescamento rapido fino a 8 metri verticali.

MODELS - MODELLI

Code - Codice	RW425BGS4 /LD62+TT	RW425AGS4 /Y388+TT	RW425AGS4 /Y488+TT
PUMP - POMPA			
RPM - Giri/min	1800	2000	2200
P MAX pump - pompa (kW)	12.5	21	28
Q MAX (m³/h)	200	200	200
H MAX (m)	25	30	37
Ø Inlet/outlet - Bocche asp./man. DN (mm -")	100 (4")	100 (4")	100 (4")
Ø Impeller - Girante (mm)	225	250	250
Free solids passage MAX size (mm)	73 x 30	73 x 30	73 x 30
Passaggio solidi MAX (mm)			
Vacuum device capacity (Nm³/h)	75	75	75
Portata depressore (Nm³/h)			

ENGINE DRIVEN - MOTORIZZAZIONE

Brand - Marca	Lombardini 9LD625-2	Yanmar 3TNV88	Yanmar 4TNV88
N. cylinders - N. cilindri	2	3	4
Displacement - Cilindrata (cc)	1248	1642	2190
Motor power - Potenza motore MAX (kW)	21	28.2	35
Cooling - Raffreddamento	Air - Aria	Water - Acqua	Water - Acqua
Fuel - Carburante	Diesel	Diesel	Diesel
Starting system - Avviamento	Electric - Elettrico	Electric - Elettrico	Electric - Elettrico

PUMP SET UP AVAILABLE - ALLESTIMENTO POMPE

Coupling versions Accoppiamento	Flexible joint Giunto elastico	Flexible joint Giunto elastico	Flexible joint Giunto elastico
Tank capacity - Capacità serbatoio (L)	650	650	650
Total weight version +TT (kg) ** Peso totale versione +TT (kg) **	500	580	620
Base frame with tank - Base con serbatoio (+BT)	✓	✓	✓
Tank trailer (+TT) heavy type manually-driven Carrello con serbatoio (+TT) tipo pesante a traino lento	✓	✓	✓

** Empty tank - Serbatoio vuoto

VACUUM-ASSISTED SELF PRIMING ENGINE DRIVEN PUMPS

MOTOPOMPE AUTOADESCANTI VUOTOASSITITE

RW425+TT

ROBUSTA
Hydraulic System

VIESSE

POMPE • ITALIA

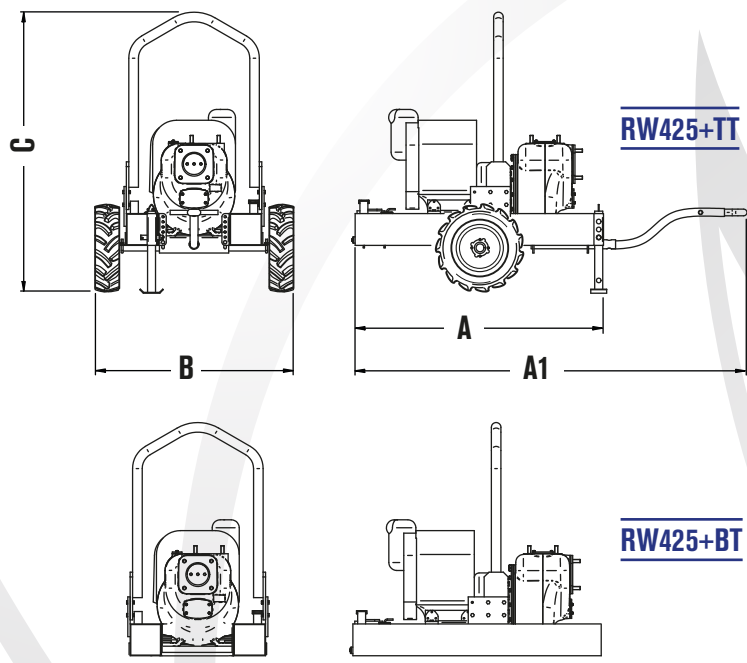
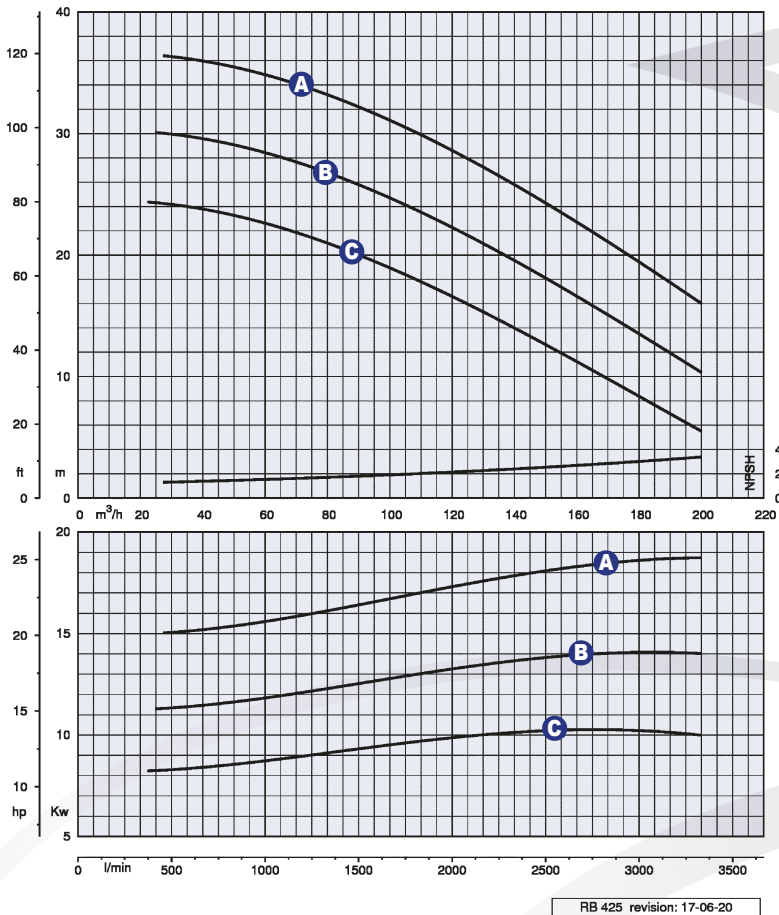

PUMP PERFORMANCE RANGE - DIAGRAMMI PRESTAZIONALI

- A** RW425AGS4/Y488+TT
- B** RW425AGS4/Y388+TT
- C** RW425BGS4/LD62+TT

Performance tests have been carried out according to UNI EN ISO 9906 Grade 2.
Tested liquid: clean water, density 1 kg/dm³.

Test eseguiti secondo la norma UNI EN ISO 9906 - livello 2.
Liquido di prova: acqua pulita, densità 1 kg/m³.

DIMENSIONS - DIMENSIONI mm

TYPE - TIPO	A	A1	B	C
+TT	220	340	160	160

Dimensions are indicative and shall not be considered binding.
Dimensioni indicative e non vincolanti.

OPTIONAL ACCESSORIES - ACCESSORI OPZIONALI

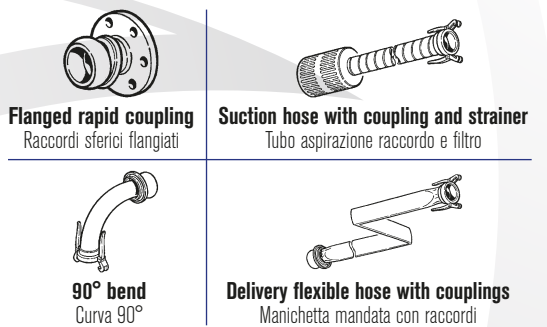

STANDARD MATERIAL OF CONSTRUCTION

Pump body	Cast Iron GJL250
Volute	Nodular cast iron GJS400
Open-blade impeller	Nodular cast iron GJS400
Mechanical Seal	Silicon Carbide/ Viton®
Shaft	Steel C40
Elastomers	Nitrile

Special metallurgies available on demand

MATERIALI STANDARD

Corpo	Ghisa GJL250
Voluta	Ghisa sferoidale GJS400
Girante a pale aperte	Ghisa sferoidale GJS400
Tenuta meccanica	Carburo di silicio / Viton®
Albero	Acciaio C40
Elastomeri	Nitrile

Altre versioni disponibili su richiesta.

10.2018 - Rev. 02-B