

VACUUM-ASSISTED SELF PRIMING ENGINE DRIVEN PUMPS

MOTOPOMPE AUTOADESCANTI VUOTOASSITITE

RW831+TT

ROBUSTA
Hydraulic System

VIESSE

POMPE • ITALIA



The vacuum-assisted pumps "Robusta", are designed to comply to the hardest and heavy duty applications, such as: building, emergency and industrial sectors. Unique in the whole world, the opened blades, double curved impeller, grants an high hydraulic efficiency. The high thickness of the casing and of the impeller blades, allow the pumping of more abrasive fluids and larger passage of solids. The great priming capacity of the vacuum device, is making, this unit, particularly suitable for wellpoint systems, having a fast and continuous priming.

FEATURES

- ✓ EN-JL1030 cast iron construction according to UNI EN 1561 with modular body.
- ✓ Replaceable screw-less armoured internal volute in EN-JS1030 nodular cast iron according to UNI EN 1563.
- ✓ Mechanical seal in high resistance hard metal.
- ✓ Large-size inspection hatches to facilitate cleaning and inspection.
- ✓ Standardised EN1092-1:2003 flanged inlet and outlet with built in threaded rod.
- ✓ Rapid self-priming up to 8 meters in vertical position.



Le pompe vuotoassistite "Robusta" sono realizzate per le applicazioni più gravose e difficili nei settori: edilizia, emergenza e industria. La girante a pale aperte e doppia curvatura, unica al mondo, garantisce un elevato rendimento idraulico. Lo spessore del corpo e delle pale della girante permettono di pompare anche i fluidi più abrasivi con elevato passaggio di corpi solidi. Il depressore ad alta capacità di vuoto permette un adescamento rapido e continuo, rendendole particolarmente idonee al servizio wellpoint.

CARATTERISTICHE

- ✓ Costruzione in ghisa EN-JL1030 secondo UNI EN 1561 con corpo modulare.
- ✓ Voluta interna corazzata sostituibile senza viti, in ghisa sferoidale EN-JS1030 secondo UNI EN 1563.
- ✓ Tenuta meccanica ad alta resistenza.
- ✓ Portine di ispezione di grandi dimensioni per facilitarne la pulizia e l'ispezione.
- ✓ Bocche flangiate norm. EN1092-1:2003 con prigionieri.
- ✓ Innescamento rapido fino a 8 metri verticali.

MODELS - MODELLI			
Code - Codice	RW831BGY49N+TT	RW831BGY498+TT	RW831AGN4S0+TT
PUMP - POMPA			
RPM - Giri/min	1700	1800	1900
P MAX pump - pompa (kW)	41	43	65
Q MAX (m ³ /h)	600	650	750
H MAX (m)	30	34	43
Ø Inlet/outlet - Bocche asp./man. DN (mm -")	200 (8")	200 (8")	200 (8")
Ø Impeller - Girante (mm)	270	270	300
Free solids passage MAX size (mm) Passaggio solidi MAX (mm)	78 x 75	78 x 75	78 x 75
Vacuum device capacity (Nm ³ /h) Portata depressore (Nm ³ /h)	75	75	75
ENGINE DRIVEN - MOTORIZZAZIONE			
Brand - Marca	Yanmar 4TNV98NS*	Yanmar 4TNV98T	FPT N45MSSX00.50
N. cylinders - N. cilindri	4	4	4
Displacement - Cilindrata (cc)	3319	3319	4500
Motor power - Potenza motore MAX (kW)	49.7	52	74
Cooling - Raffreddamento	Water - Acqua	Water - Acqua	Water - Acqua
Fuel - Carburante	Diesel	Diesel	Diesel
Starting system - Avviamento	Electric - Elettrico	Electric - Elettrico	Electric - Elettrico
PUMP SET UP AVAILABLE - ALLESTIMENTO POMPE			
Coupling versions Accoppiamento	Direct / Monobloc Diretto / Monoblocco	Direct / Monobloc Diretto / Monoblocco	Direct / Monobloc Diretto / Monoblocco
Tank capacity - Capacità serbatoio (L)	650	650	650
Total weight version +TT (kg) ** Peso totale versione +TT (kg) **	1100	1100	1150
Base frame with tank - Base con serbatoio (+BT)	✓	✓	✓
Tank trailer (+TT) heavy type manually-driven Carrello con serbatoio (+TT) tipo pesante a traino lento	✓	✓	✓

* Stage 2 motor, not suitable for European market - Motore stage 2, non idoneo al mercato europeo
** Empty tank - Serbatoio vuoto

VACUUM-ASSISTED SELF PRIMING ENGINE DRIVEN PUMPS MOTOPOMPE AUTOADESCANTI VUOTOASSITITE

RW831+TT

ROBUSTA
Hydraulic System

VIESSE

POMPE • ITALIA

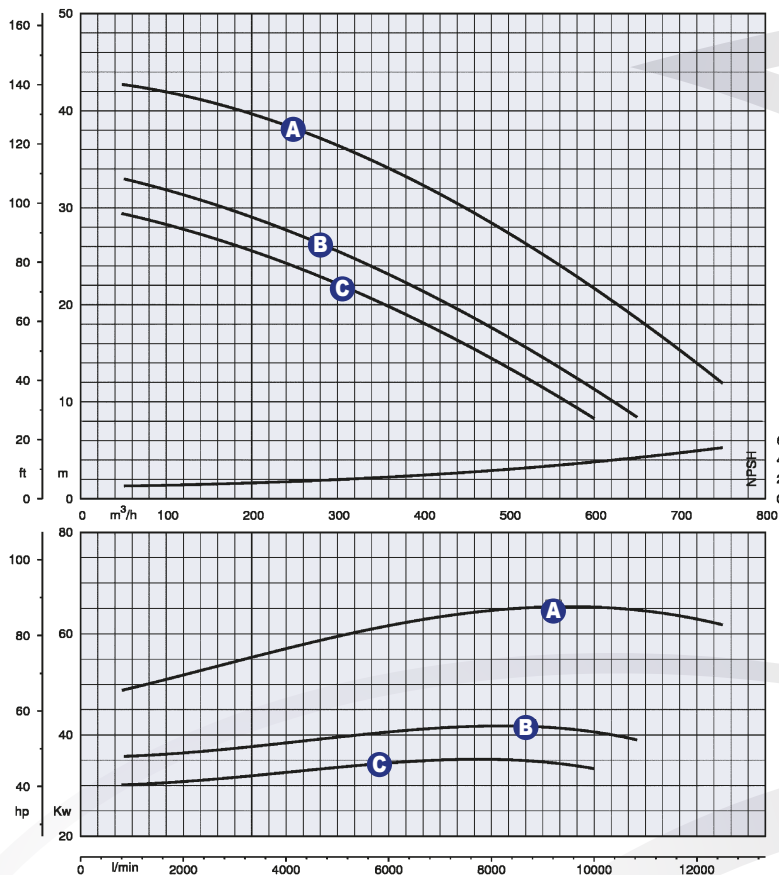

RB 831 revision: 18-07-30

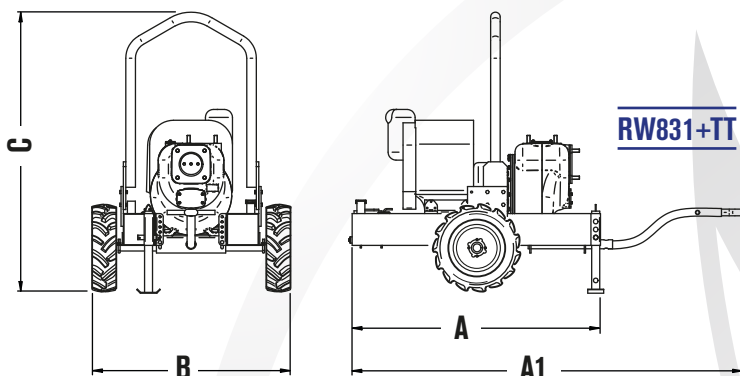

RW831+TT

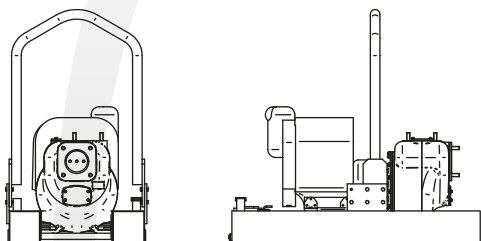

RW831+BT

PUMP PERFORMANCE RANGE - DIAGRAMMI PRESTAZIONALI

A RW831AGN4S0+TT

B RW831BGY498+TT

C RW831BGY49N+TT

Performance tests have been carried out according to UNI EN ISO 9906 Grade 2.

Tested liquid: clean water, density 1 kg/dm³.

Test eseguiti secondo la norma UNI EN ISO 9906 - livello 2.

Liquido di prova: acqua pulita, densità 1 kg/m³.

DIMENSIONS - DIMENSIONI mm

TYPE - TIPO	A	A1	B	C
+TT	220	340	160	160

Dimensions are indicative and shall not be considered binding.
Dimensioni indicative e non vincolanti.

OPTIONAL ACCESSORIES - ACCESSORI OPZIONALI



Flanged rapid coupling
Raccordi sferici flangiati



Suction hose with coupling and strainer
Tubo aspirazione raccordo e filtro



90° bend
Curva 90°

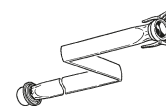

Delivery flexible hose with couplings
Manichetta mandata con raccordi

STANDARD MATERIAL OF CONSTRUCTION

Pump body	Cast Iron GJL250
Volute	Nodular cast iron GJS400
Open-blade impeller	Nodular cast iron GJS400
Mechanical Seal	Silicon Carbide/ Viton®
Shaft	Steel C40
Elastomers	Nitrile

Special metallurgies available on demand

MATERIALI STANDARD

Corpo	Ghisa GJL250
Voluta	Ghisa sferoidale GJS400
Girante a pale aperte	Ghisa sferoidale GJS400
Tenuta meccanica	Carburo di silicio / Viton®
Albero	Acciaio C40
Elastomeri	Nitrile

Altre versioni disponibili su richiesta.

10.2018 - Rev. 02-B